

Viktor S. Chabaniuk¹, Kateryna A. Polyvach²

CARTOGRAPHIC INTERPRETATION OF THE “META” NOTION IN THE CULTURAL HERITAGE CONTEXT

ABSTRACT

The monograph [Aslanikashvili, 1974] does not define the term “metacartography”, although the notion itself is described in sufficient detail to be understood. A. Aslanikashvili’s metacartography has proven to be very useful in considering the relations between modern systematic cartographic phenomena, which are often relate to Web 2.0 cartography. The article offers a practical interpretation of the “meta” notion in such phenomena as National Atlases, National Spatial Data Infrastructures and OpenStreetMap. This is done using the Conceptual Frameworks (CoFr) method and the Atlas Extender (AtEx), which allow extending atlases in the classical sense to extended atlas systems. AtEx implements a CoFr method of relational cartography based on patterns (hereinafter RelCa), among which are relational patterns of “meta”. CoFr describe the structure of spatial information systems in an extended sense, and relational cartographies are defined as the coordinated art, science and technology of making and using relations in (extended) cartographic systems and between (extended) cartographic systems. Due to this we can consider relational spaces that have a lot in common with the specific spaces of A. Aslanikashvili.

To apply the RelCa methods, the understanding of “metacartography”, “map meta-model” and “map language” notions have been updated. For this purpose, Model-Based Engineering (MBE) has been used, an area of computer science that is evolving in our century. The analogies between BMI constructions, modern systematic cartographic phenomena and A. Aslanikashvili metacartography are shown. It has been proved abductively that in modern conditions the field of cartography research needs to be extended by relational spaces or to a system of spatial systems of a certain epistemological structure. Important in this structuring is the relation of “meta” that A. Aslanikashvili began to explore. The abduction proved the presence and necessity of using the “meta” relation when constructing cultural heritage maps. In particular, the interpretation of the “meta” relation for choropleth maps is proposed, modeling the saturation assessment of the country by the entities of the material cultural heritage. The results obtained will be included in the Atlas of Cultural Heritage of Ukraine.

KEYWORDS: relational cartography, metacartography, Conceptual Frameworks method, Atlas Extender, Atlas of Cultural Heritage

INTRODUCTION

The article offers an interpretation of the notion of “meta”, which allows us to better understand and apply in modern cartographic practice the terms and notions of “metacartography” and “meta-model of the map” from the monograph [Aslanikashvili, 1974]. A. Aslanikashvili does not defined the terms “meta” and “metacartography”, although the notion of “metacartography” is clearly and coherently stated in terms of the three major components of science [Klir, 1985], if to understand the cartography as a science: 1 — a *domain* of inquiry, 2 — a body of *knowledge* regarding the domain, 3 — a *methodology* for the acquisition of new knowledge within the domain. In component 2 A. Aslanikashvili introduced and described the notion of “meta-model of map”, which is used in the modeling of specific spaces from component 1. The basis of component

¹ Institute of Geography of NASU, Volodymyrska str., 44, 01030, Kiev, Ukraine; e-mail: chab3@i.ua

² Institute of Geography of NASU, Volodymyrska str., 44, 01030, Kiev, Ukraine; e-mail: kateryna.polyvach@gmail.com

3 according to [Aslanikashvili, 1974] is cartographic modeling. The notion of “meta-model of map” is closely related to the notion of “language of map”. Therefore, in addition to the constructs “meta” and “metacartography”, the work also focuses on the term and the concept of “language of map”.

The term “meta” as a prefix to the term “data” has long been used in the creation of corporate or national spatial information systems (SpIS). Examples of the latter are National Atlases (for example, the Electronic version of the National Atlas of Ukraine — EINAU [National..., 2007]), as well as the Atlas of Cultural Heritage of Ukraine (AtCH), which is being created in the Institute of Geography of NASU [Cultural..., 2018]. These SpISs are used by more than one user, so system need to have such information about the system data so that it is understood equally by all users. In informatics (computer science) at the end of the last century, the term “metadata”, which came from the theory and practice of databases, was designated to denote such information: “The description of the data is known as the system catalog (or data dictionary or metadata — the ‘data about data’). It is the self-describing nature of a database that provides program-data independence” [Connolly *et al.*, 1995, p. 15; Connolly, Begg, 2015, p. 63]. Note that in the twenty years between the 1st and 6th editions of the monograph, the definition of the term has not changed.

Geoinformatics is also currently operating mainly on spatial data metadata. One of the last definitions is: “Geographic information metadata (GI-metadata) are data describing geographic information resources ... GI-metadata were shown on printed maps to describe, for instance, the scale of the map, the data sources used for map compilation, the extent of the map, the datum, and the coordinate reference system” [Brodeur *et al.*, 2019, p. 39]. However, a descriptive understanding of metadata is further extended in the same paragraph: “... Now with the Internet, the Web, and the Semantic Web, GI-metadata have become an underpinning resource for the discovery, the retrieval and the appropriate use of geographic information resources. They are essential for enabling collaboration between users of geographic information that interact together towards a common end, as well as for sharing and exchanging information, i.e., interoperability”.

The definition of metadata as “data about data”, in addition to the above, is generally known (see, e.g., <https://en.wikipedia.org/wiki/Metadata>, accessed 2019-dec-22). Thanks to this popularity, they have long de facto defined the term and the notion of “meta” in informatics and geoinformatics. Such a “descriptive” definition of the term “meta” is even fixed in ISO/IEC/IEEE 24765:2010: “Meta — a prefix to a concept to imply definition information about the concept”. However, the cited source, which is the “Systems and Software Engineering — Vocabulary” as of 2010, no longer has the term “metadata”. In fact, a “descriptive” understanding of the term and the notion of “meta” is no longer sufficient for use in modern information and spatial information systems. For example, the term “metamodel” in ISO/IEC/IEEE 24765:2010 has the following definitions: “**1.** a logical information model that specifies the modeling elements used within another (or the same) modeling notation” or “**4.** specification of concepts, relationships and rules that are used to define a methodology”. It is unlikely that these definitions can be reduced to the term “model about models” and its understanding, which follows from a “descriptive” understanding of the terms “meta” and “metadata”.

For the definition of the term “model” above, we can use the following definitions in ISO/IEC/IEEE 24765:2010: “**2.** a representation of something that suppresses certain aspects of the modeled subject” or “**4.** a related collection of instances of meta-objects, representing (describing or prescribing) an information system, or parts representing, such as a software product” or “**5.** a semantically closed abstraction of a system or a complete description of a system from a particular perspective”. Here are three of the five model definitions from ISO/IEC/IEEE 24765:2010. Some of them use other terms, such as “meta-objects”. Instead of defining these additional terms, let us note that there are many more definitions of the term “model”. Therefore, we advise not to forget about the three mantras known in informatics: “anything is a model (system, object)”.

Another example of the inadequacy of the practically formed “descriptive” understanding of the term “meta” is its use in the term “metacartography”. The last term is not enough to

understand only because of the understanding of the components of “meta” and “cartography”. On the contrary, referring to a quote from [Aslanikashvili, 1974, p. 5], A. Liuty states that “A.F. Aslanikashvili referred to the term “metacartography” as a general theory of cartography (rather, metatheory), which by its vision should “integrate” into a single logical and methodological system all its sections and substantiate the place of this science in the general epistemological system of sciences” [Liuty, 2002, p. 292]. From this quote it is clear that according to A. Liuty, metacartography is not just a description of cartography or “cartography about cartography”.

There [Liuty, 2002, p. 292] said, “The conception of A.F. Aslanikashvili metacartography should be distinguished from the metacartography, outlined by W. Bunge. The latter focuses its “interests” on the questions: what spatial dependencies and properties can maps display as one of the possible tools for displaying spatial properties, how well they display and in what respect other means will be more suitable” [Bunge, 1967, p. 60]. W. Bunge also did not define the term “metacartography”.

Thus, it is necessary to state the theoretical problem: to understand the term and the notion of “metacartography” is not enough to understand only the terms and the notions of “meta” and “cartography”. Both the constituents and the term and the notion of “metacartography” need additional information for understanding. This article provides just such additional information that actually represents the specific knowledge of the subject.

A. Aslanikashvili’s main monographs were published in the 1970s, when modern systematic cartographic phenomena did not exist yet, which are practically useful and are combined with the theme “Web 2.0 cartography”. That is, modernity poses to cartography not only theoretical, but also practical systemic cartographic problems. Examples are the problem of determining the relation between the AtCH and the National Spatial Data Infrastructure (NSDI), as well as between the AtCH and known cartographic platforms such as OpenStreetMap (OSM) and Google Maps. We believe that a better understanding of the cartographic “meta” relation explored in this paper will allow us to work more effectively with the relations between the systems listed.

MATERIALS AND METHODS OF RESEARCHES

D. Hay [2006, p. 2] believes that after decades of using “there is still no simple, clear description of metadata in a form that is both comprehensive enough to cover our industry and comprehensible enough that it can be used by people” and his monograph is an attempt to provide such a description. He cites the following extensions that extend the simplistic “descriptive” understanding of metadata as “data about data”:

1. Any data about the organization’s data resource [Brackett, 2000, p. 149] (cited in [Hay, 2006]).
2. All physical data and knowledge from inside and outside an organization, including information about the physical data, technical and business processes, rules and constraints of the data, and structures of the data used by a corporation [Marco, 2000, p. 5].
3. The detailed description of instance data. The format and characteristics of populated instance data: instances and values, dependent on the role of the metadata recipient [Tannenbaum, 2001, p. 93] (cited in [Hay, 2006]).

After discussing these cites, D. Hay proposes the following definition: “Metadata is the data that describes the structure and workings of an organization’s use of information, and which describes the systems it uses to manage that information” [Hay, 2006, p. 2]. Equally important to us is the hierarchy of knowledge about metadata, which is factually fixed in the figure [Hay, 2006, fig. 1-1]. Namely, from the bottom up, this hierarchy is shown as follows (fig. 1-1): Things of the real world $\uparrow\downarrow$ Data about things of the real world (database) $\uparrow\downarrow$ Data about the database (data model) $\uparrow\downarrow$ Elements of metadata (model metadata).

It should be said that ISO/IEC/IEEE 24765:2010 uses the terms meta-attribute, meta-entity, meta-relation, as well as other meta-concepts which are now used in the field of informatics, called Model-Based Engineering (BME) [Brambilla et al., 2017]. The BME uses a hierarchy of models

of at least four tiers: MDA $\uparrow\downarrow$ MDD $\uparrow\downarrow$ MDE $\uparrow\downarrow$ BME. It uses bottom-up ordering (denotation — $\uparrow\downarrow$) of tiers and such their elements: MDA — Model-Driven Architecture, MDD — Model-Driven Development, MDE — Model-Driven Engineering. The BME uses the “anything is a model” mantra and the hierarchy of models for the four tiers and the system under study (sus) is as follows: sus $\uparrow\downarrow$ model $\uparrow\downarrow$ meta-model $\uparrow\downarrow$ meta-meta-model.

However, in this article we use an even more general understanding of the term “meta” from the general systems theory [Klir, 1985]. There, Chapter 5 “Metasystem” says that the prefix “meta” has Greek origins. In Greek, it has three main meanings:

1. “meta X” is the name of something that happened *after* X, that is, X is a prerequisite for meta X;
2. “meta X” indicates that X is changing and is the name of that *change*;
3. “meta X” as a name for something that is *above* X in the sense that it is more highly organized, of a higher logical type, or viewed from a larger perspective (transcending).

In our research, to deepen the understanding of the cartographic term “meta”, we consider the relations between Spatial Information Systems (SpIS) and their metasystems (metaSpIS). Thus, SpIS are understood in two senses: narrow (n) and broader (b). SpISn are “traditional” subject SpIS: paper atlases, electronic atlases (EAt), atlas information systems (AtIS), cartographic information systems (CIS), and geographic information systems (GIS). They are called subject because in their creation were used paradigms (or conceptions according to [Liuty, 2002]) of cartography, whose subject of research (domain of inquiry) is a map.

SpISb in general [Information..., 1989] is a collection of all formal and informal representations of data, including spatial ones, and activities with them in the organization, including those associated with the first and second interchanges, both internal and external. If one starts looking for a structure in SpISb, then perhaps the first one is most likely to find a structure that is determined by the SpISn $\uparrow\downarrow$ metaSpISn relation. Thus, the above definition of metadata from [Marco, 2000, p. 5] practically coincides with the definition of an information system in a broader sense from [Information..., 1989]. Therefore, the above-mentioned constructions from monograph [Hay, 2006] are applicable to the SpIS, as well as the BME constructions. In particular, the next relations are fair: SpISn $\uparrow\downarrow$ metaSpISn $\uparrow\downarrow$ meta²SpISn $\uparrow\downarrow$ meta³SpISn, where meta³= meta-meta²=meta-meta-meta.

The term and the notion of SpISb was introduced to represent modern SpIS, including, for example, OSM or NSDI. Both the SpIS structure in general and certain relations between individual SpISb structures are repeated in many “large spatial” projects. The most important recurring relations are the so-called epistemological relations. They are difficult to understand because their analogs in reality are not obvious. However, first you need to understand what the relation “X” $\uparrow\downarrow$ “meta X” means. In the given above links this relation is not mentioned — the properties “X” or “meta X” are defined and that’s all.

At the same time, we have a lot of evidences of the typicality (repeatability) of relations “X” $\uparrow\downarrow$ “meta X”, which only in the second queue depends on the properties of “X” and “goal X”, and in first queue depends on something else. Some of these evidences are cited above. There are many evidences in works on the BME and in the monograph [Chabanyuk, 2018] on Relational Cartography (RelCa). In general, first of all, these relations depend on the knowledge that exist (and can be found or not found) between “X” and “meta X”. On this rather simple fact, in RelCa is based an introduction of epistemological relations between elements of adjacent strata, if we mean the elements of systems, or between elements of neighboring echelons, if instead of strata to mean organizational elements and organizations themselves not only as real, but also as virtual. The executions for some fixed SpISn and its SpISb are called bottom-up: Operating $\uparrow\downarrow$ Application $\uparrow\downarrow$ Conceptual $\uparrow\downarrow$ General. In this case, SpISn belong to the Operational Stratum, and other constituents of SpISb belong to other strata, in addition to the Operational Stratum.

We are interested in relations in the SpIS that model relational spaces [Cresswell, 2013] or the Spatial Systems (SpS) of the outside world. SpS can be physical, abstract-physical, abstract,

or any combination thereof. The notion of physical SpS coincides with the notion of “specific spaces” [Aslanikashvili, 1974]. In addition, there are many problems that can be solved with the help of general systems theory. In this case, the SpIS needs to be converted (abstracted) into a general SpS. To do this, we use the results of two monographs on general systems theory: [Klir, 1985; van Gigch, 1991].

In summary, let us say that we are interested in the epistemological relations between models or systems of spatial information systems in a broader sense. We are also interested in: 1) images of epistemological relations between SpIS in SpISb in the outside world — between SpS in SpSb of reality, 2) images of epistemological relations between general SpS in general SpSb. If we supplement the epistemological relations with transformational and evolutionary ones, then their Conceptual Framework (CoFr) will be justified for a sufficiently large class of SpIS [Chabanyuk, 2018]. Hereinafter, CoFr of Atlas systems in a broader sense (AtSb) is used.

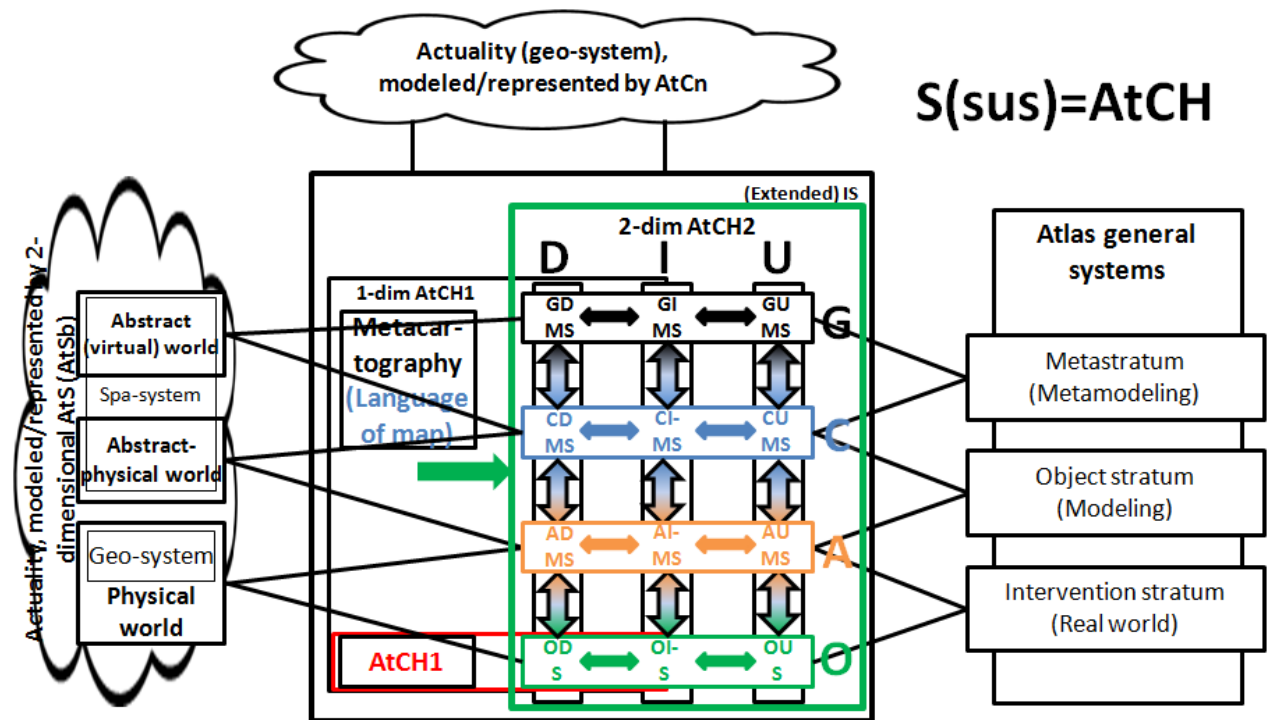

Fig. 7. AtSb structure for $S(sus)=AtCH$

Note that by [Booch et al., 2001], a pattern is a typical solution to a typical problem in a given context. The framework is called an architectural pattern. We use these definitions most often. However [Alexander, 1979, p. 247] also provides the following definition: “Each pattern is a three-sided rule that expresses the relation between a particular context, a problem and a solution”. That is, a pattern is both a thing that happens in the world and a rule that tells how to create a thing and when to create it. It is both a process and a thing; at the same time a description of an existing thing and a description of the process that generates the thing. Therefore, when we call the term “meta” as a pattern or relation, we are referring to this three-sided rule. So, the “SpISn $\uparrow\downarrow$ metaSpISn” record tells us that there is a two-way relation between some SpISn and metaSpISn. The relation \uparrow is most commonly called as classification (instanceOf) [Favre, 2006] between a SpISn instance and a metaSpISn class. In this case, we first have a SpISn instance and classify it using the relation (process) \uparrow . The result is a metaSpISn class. The relation \downarrow is most commonly called as instantiation [ibid.] between a metaSpISn class and a SpISn instance. In this case, we

first have a metaSpISn class and execute (construct) an instance SpISn using the relation (process) ↓.

If we apply AtSb CoFr to AtCH, we get fig. 1, which shows the relation between the static (subject) AtCH (AtCH1) and dynamic (extended) AtCH (AtCH2 or some AtCb). Let us explain the reduction of elements in the rectangle “2nd AtCH2”:

- The letters D, I, U from above indicate the levels of AtCH2: D — Datalogics, I — Infologics, U — Usagelogs. The letters G, C, A, O on the right indicate the strata of AtCH2: G — General, C — Conceptual, A — Application, O — Operational.
- XYMS, where X = D, I, U; Y = G, C, A, O; stands for XY M(odel) of S(us). For example, DCMS stands for Datalogical (D) Conceptual (C) Model (M) of the S (sus, which in this case is AtCH).

Simplified process of application of the AtSb CoFr method on the example of AtCH2 is shown in fig. 2. It is stated here that at the beginning we have a class of Atlas systems in the extended sense, the structure of which is described by AtSb CoFr. An example of this class is the extension of EINAU. Since EINAUb is a two-dimensional AtS, our task is to find such models in AtCH2 (AtCHb) that would satisfy the cultural heritage context and at the same time fit the structure of EINAUb. Since two-dimensional AtCHb will be quite complex SpISb, a static AtCH1 will first be created, as well as several prototypes of the dynamic atlas AtCH2. AtEx was used to build the first such prototype. This prototype is not yet a prototype of AtCHb, but it is an approximation and some explanation of the dynamic AtCH2.

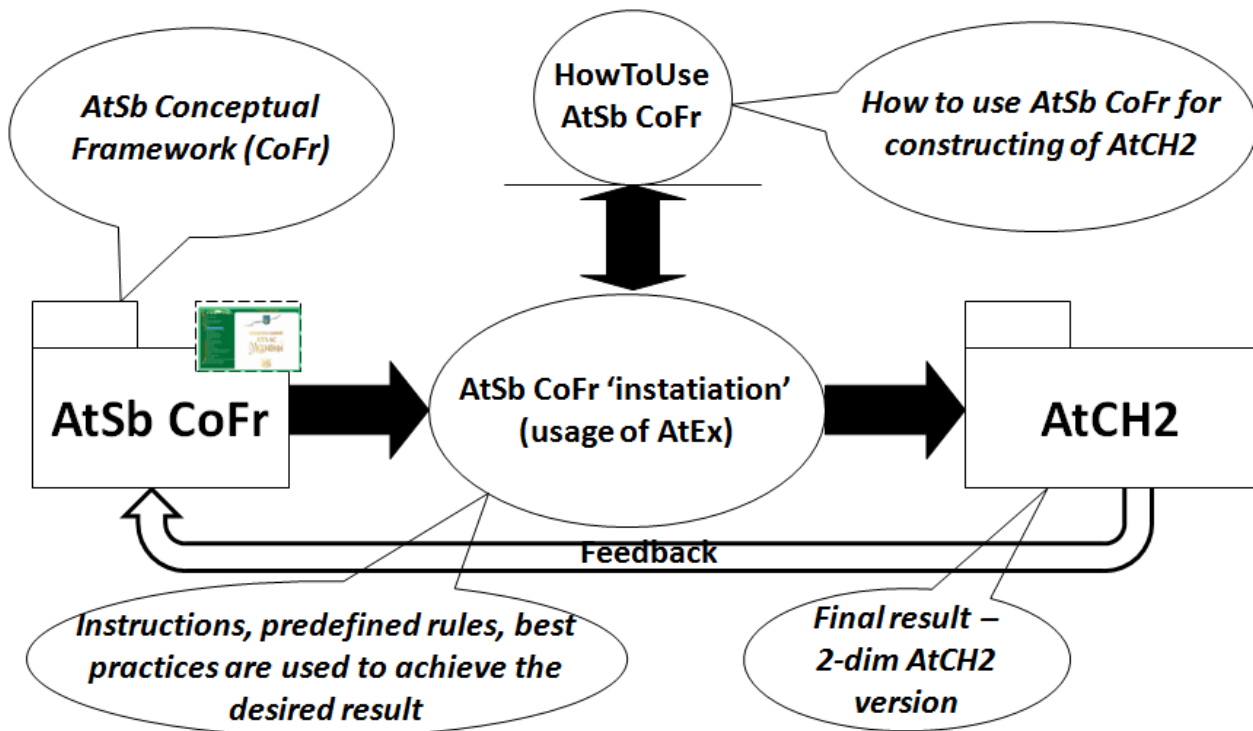

Fig. 2. AtSb CoFr method on the example of AtCH2

The mentioned and other results of BME and RelCa were used to update the concepts of “meta-cartography”, “meta-model of the map” and “map language”. In practice, a tool called the Atlas Extender AtEx [Chabaniuk, Rudenko, 2019] was used to interpret the updated theoretical results. AtEx was created to visually visualize the conceptual frameworks (CoFr) of Spatial Information Systems (SpIS) being investigated in RelCa. In this work, the context of cultural heritage (CH) is selected and domains of two applications are considered: atlases of static (AtCH1) and

dynamic (AtCH2) types. An instance of the class of atlases of the classical static type is the Atlas of Cultural Heritage, which is a subsystem of the Atlas “Population of Ukraine and its Natural and Cultural Heritage” (hereinafter referred to as AtCH1). This Atlas is currently being created at the Institute of Geography of the NAS of Ukraine. The Classical Dynamic Type Atlas (hereinafter referred to as AtCH2) must be a subsystem of the “Electronic material accounting, conservation and development monument of the material CH. A pilot project for such a system is currently being developed in Ukraine.

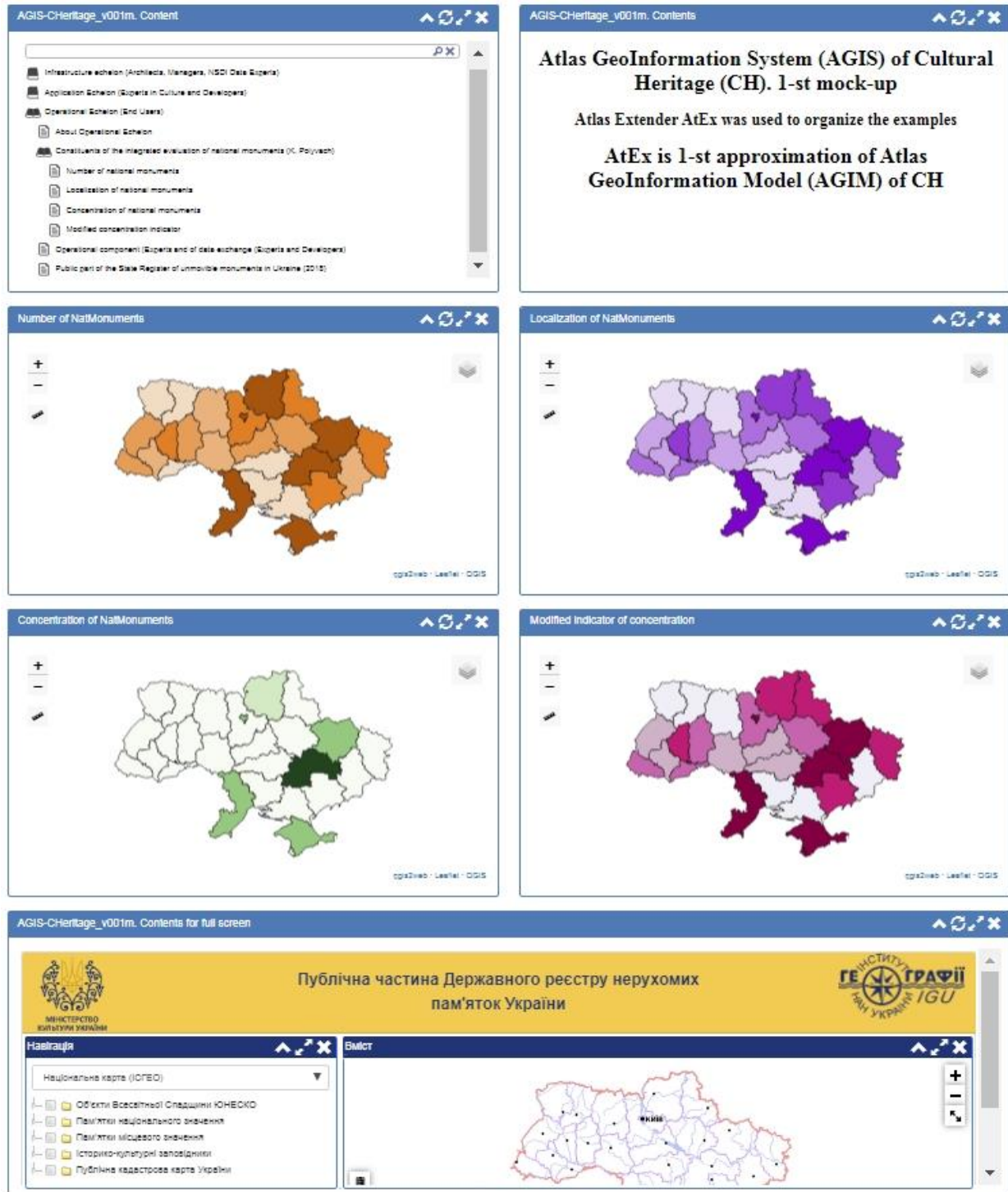

Fig. 3. Starting page of the prototype

Shown in fig. 1 AtCH1 is “subject” or “classical”. It is formed on the basis of “subject cartography”. In order to explain our understanding of these terms, let us consider in more detail the concept of extension of classical SpIS, among which the most famous are the classes EA, AtIS, CIS and, even, GIS. We do not want to start a discussion here, but note, for example, that both records are true for us: $CIS \subset GIS$ and $GIS \subset CIS$. As a rule, everyone thinks that $CIS \subset GIS$ is because GIS have many more functions than CIS. However, it is unclear why the $GIS \subset CIS$ record may be incorrect if the map visualization functions are taken into account. These features are in both systems, so the second entry is also true, only from a different perspective. A special prototype for this article was developed (fig. 3).

RESULTS OF RESEARCHES AND THEIR DISCUSSION

Unfortunately, in the current century, neither the Language paradigm of Cartography nor Metacartographies of A. Aslanikashvili and W. Bunge have not yet developed. However, the field of informatics, known as the BME, began to develop intensively. BME is successfully applied to spatial systems of reality, which form the domain of inquiry of spatial information systems (SpIS). Modern practice is giving rise to more and more such systems and, as a result, not only theoretical but also practical questions that need to be answered.

We are addressing one such issue at the BME, which allows us to better understand the domain of metacartography inquiry. Therefore, to refine this understanding from a large number of sources, we use only the article [Karagiannis, Kuhn, 2002]. To learn about the cartographic term and notion of “meta” we use abduction with AtEx. We use the monograph [van Gigh, 1991] to structure the general SpS (see right side of fig. 1), although we do not research them in this work. However, epistemological structuring according to [van Gigh, 1991] helps to better understand the relations between metacartography and cartography, or between metamodeling and modeling, so we left it. The result of the research is shown in fig. 4.

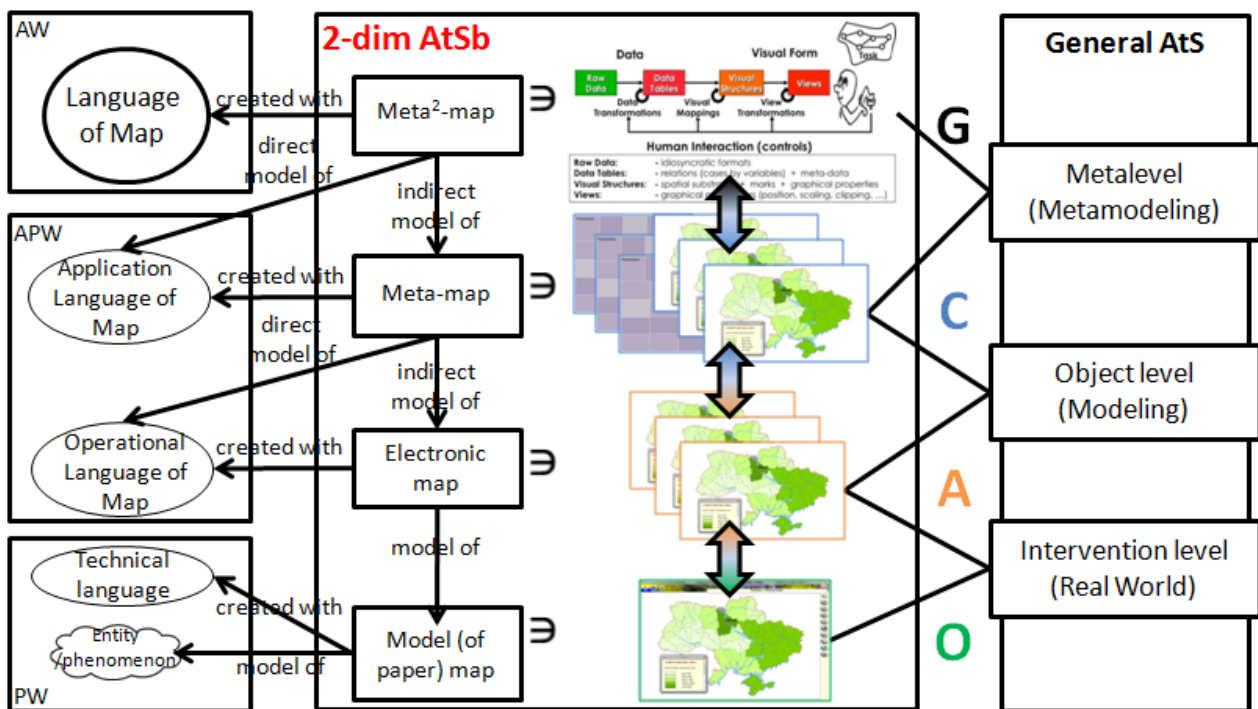

Fig. 4. The result of the research work

Domain of inquiry

Below is a clarification of the domain of inquiry from Fig. 1 — left part Fig. 4, where the results and the figure [Karagiannis, Kuhn, 2002, p. 182, fig. 3] are used. We only comment on changes compared to the original figure. Abbreviations: PW — Physical world, APW — Abstract-physical world, AW — Abstract world. Other abbreviations are above.

The “Model (of paper) map” replaces the “Original” in the original figure. In fact, there may not only be a paper map, but also a modeled “entity/phenomenon”. To retain similarity to the original figure, a “Technical language” is used, which is used to obtain a paper map. This change is made to take into account the real situation with EINAU [Rudenko et al., 2007]. The fact is that three of the five EINAU thematic blocks are made of paper maps that were produced outside the EINAU 2007 project. To manipulate these maps in EINAU, its cartographic software component isgeoMap has been refined. The revision concerned the ability to manipulate SWG files using the Adobe Flesh plugin. The result is a “static” electronic Operational Stratum map displayed by the isgeoMap component, or a paper map model rendered in the Technical language. It should be reminded [National..., 2007] that EINAU 2000 and 2007 were supplied on optical magnetic media and did not allow editing (change) of maps by the end user during operation. One of the maps in the EINAU 2000 interface is shown in the graphics column on Operation Stratum.

An “Electronic map” is shown on the place of “Model” created using the “Modeling Language”. Instead, this language shows “Operational Lang. of Map”, which defines the “Electronic map”. Operational Lang. of Map can be considered as the cartographic language of many EINAU 2007 maps in the format of the geo-information package MapInfo Professional. Both the MapInfo Professional map and the associated cartographic language are referred to as Application Stratum. In the EINAU 2007 project, maps of two of the five thematic blocks were prepared by developers in MapInfo Professional’s geo-information package. These maps were editable. Both the attributes and methods of a particular class of maps could change. About the same can be said for maps in Adobe Illustrator format. Therefore, we can assume that a static electronic map is an instance of a certain class of Application Stratum. In practice, this relation is more complicated, but we do not detail it here.

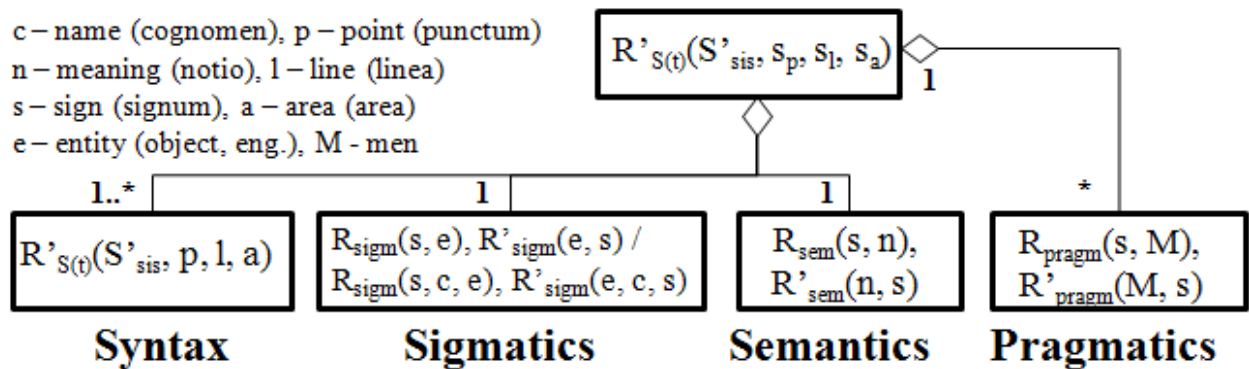

Fig. 5. The meta-model of the map following [Aslanikashvili, 1974]

“Application Lang. of Map” replaces “Metamodeling Language” in the original. This language defines “Meta-map” instead of “Metamodel” in the original. In the case of EINAU 2007, MapInfo MapBasic can be considered as such language for two of the five thematic blocks. As is known from the monograph [Aslanikashvili, 1974], the meta-model of the map aggregates Syntax, Sigmatics, Semantics and Pragmatics (fig. 5). Using fig. 4 “Modeling language determination” from [da Silva, 2015, p. 143], we get a Language of Map view like in fig. 6. With the exception of Abstract Syntax, this scheme almost coincides with the vision of a meta-model of the map following [Aslanikashvili, 1974]. At the end of the description of the left part fig. 4 note that the “Language of Map” can correspond to the Language of Map system described in the monograph [Liuty,

2002], and “Meta-map” or “Meta²-map” can be a meta-model of the map according to A. Aslanikashvili (fig. 5). We use the word “can” here, because neither the Language of Map of A. Liuty nor the meta-model of A. Aslanikashvili’s map have modern analogues, so these elements are desirable.

In the caption to fig. 6 (Application) is enclosed in parentheses, since the original considered “Modeling Language”. However, this figure is true for all strata modeling languages. Therefore, the “Application” stratum can be replaced by the “Operational” stratum. The Language of A. Liuty map is shown in the theoretical General Stratum, since this language has not been implemented in some way, so it cannot be called an application. It should not be forgotten that application languages are used when creating a specific information application. By this logic, the meta-model of A. Aslanikashvili’s map may also be the “Meta²-map”.

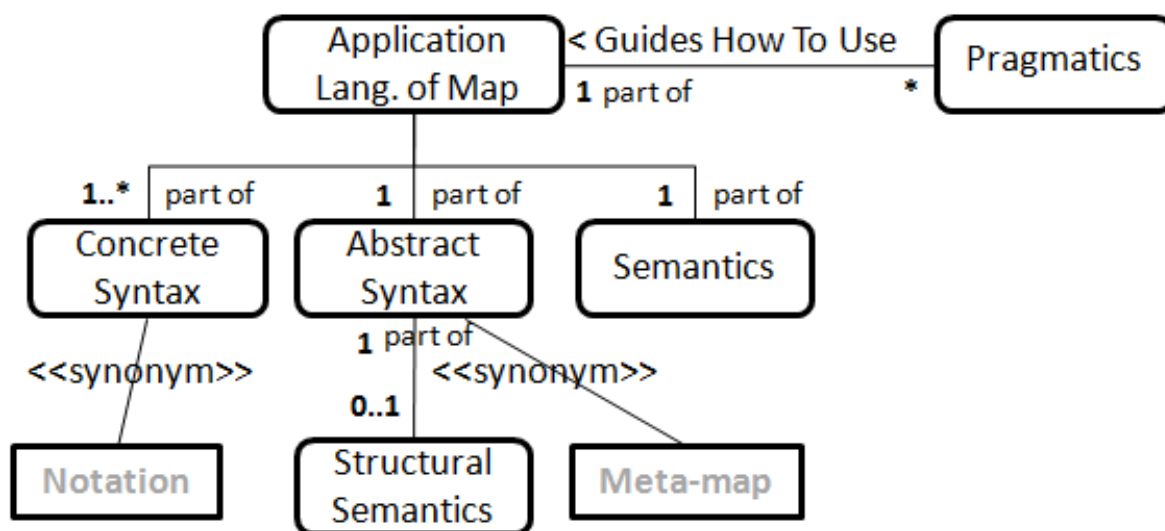

Fig. 6. Vision of (Application) Language of Map by [da Silva, 2015, p. 143, fig. 4]

In conclusion, we note that in fact we have outlined the abductive conclusions that are based on our experience in creation of AtS in the last 20 years. Apparently, these same conclusions also need more rigorous evidence.

Practical interpretation of “meta” knowledge

Practical interpretation of epistemological extension will be done using an example for a context called Cultural Heritage (CH) and for the AtCH2 Domain. It is based on the results of two monographs: “Cultural Heritage and its Impact on the Development of the Regions of Ukraine” [Polyvach, 2012] and “Cultural Heritage in the Atlas of Geoinformation System of Sustainable Development of Ukraine” [Rudenko et al., 2018].

The first monograph shows the role of the CH in the socio-economic development of regions and settlements, with differentiation at the regional and local levels. The current state and peculiarities of the territorial organization of the historical and cultural potential of the regions of Ukraine are analyzed. A method for assessing the impact of the CH on the development of the territory was developed and tested. The results of the study are presented as a series of thematic maps. The second monograph proposes the Atlas Geoinformation Model (AGIM), as well as its application to the material CH as the basis for the future Atlas Geoinformation System (AGIS) of Sustainable Development of Ukraine (AGIS-CH). AGIM is an information system in the broad sense (ISb) and is therefore referred to as AGIMb. The system to be created using the AGIMb model will be called AGISb. Its subsystem should be AtCH2.

To combine the subject [Polyvach, 2012] and relational [Chabaniuk, 2018] approaches to the modeling of relational spaces of reality, a prototype of the future AtCH2 in AGIS-CHb was

made (fig. 3). It is still very simple, but it allows us to understand: 1) the main differences between AtCH1 and AtCH2, 2) the essence of epistemological extension, 3) practically explain the notion of “meta”.

The lower part of the AtCH2 prototype corresponds to one of the results of the monograph [Polyvach, 2012]. Let us briefly describe it. The basis of this part of the methodology for assessing the cultural heritage of the territory of K. Polyvach is based on an assessment of the spatial analysis of the location of cultural heritage objects (in this case, heritage entities from the State Register of Immovable Monuments of Ukraine), namely:

- indicator of the **number of cultural heritage entities in the territory** (calculation of partial ratings);

- indicator of **concentration of cultural heritage entities per unit area** (population) of the territory (calculation of partial ratings);

- modified concentration of cultural heritage entities (W):

$W = V/B \ln B$, where W — a modified indicator; V — the absolute number indicator of entities; $B = \sqrt{SP}$ (S — area of the research area; P — population of the territory) (calculation of partial ratings);

- coefficient of localization of cultural heritage entities (Cloc):

$C_{loc} = C_{CH} / C_s$, where C_{CH} — the proportion of the territory by the number of cultural heritage entities; C_s — the specific weight of the territory by area (calculation of partial rating estimates).

The rating is calculated in the following order:

1. Determination of deviation, $Z_{ij} = X_{ij} - X_{ij \text{ mid}}$, where X_{ij} — the i-th index of the j-th region, $X_{ij \text{ mid}}$ — the middle value indicator, Z_{ij} — the deviation from the middle value indicator, and based on that,

$$Y_{ij} = (Z_{ij} - \min Z_{ij}) / (\max Z_{ij} - \min Z_{ij}), \quad (1)$$

where $\min (\max) Z_{ij}$ — the minimum (maximum) value of the deviation, $i = \text{const}$,

Y_{ij} — the standardized value (score) of X_{ij}

2. The calculation of the partial rating of a region by defined groups of indicators is carried out according to the formula of arithmetic mean standardized values.

3. The calculation of the overall rating of the region is carried out as the weighted average of the partial ratings by groups:

$$R_j = \sum R_{kj} * f_k, \quad (2)$$

where R_j — general rating j-th region,

R_{kj} — partial rating j-th region by k group of indicators, f_k — the weight k group of the scorecard, herewith $f_k \in [0;1]$, $\sum f_k = 1$.

In the analysis of the results of calculations characterizing a particular region of Ukraine, used score points — 1-5 points according to belonging to a particular interval of values and ratios: the lowest value corresponds to 1 point, below the average — 2 points, the average — 3, higher than average — 4, highest — 5 points.

The result of the analysis of the obtained indicators is a comparative cartographic model (fig. 3). For example, in the lower left window of “Number of Monuments” in fig. 3 shows a five-point choropleth built in the 2643 (Dnipro region) and 26 (Rivne region) values, which visualizes the number of monuments. The bottom right window of Localization of Monuments shows a five-point vertex, which characterizes the localization of cultural heritage entities (in the range of 0.07 to 78.51).

As we can see, the highest indicators of spatial analysis of the location of cultural heritage entities from the State Register of Immovable Monuments of Ukraine are permanently observed in the eastern and southern regions of Ukraine, as well as in Kyiv. The lowest values are observed in the regions of Northern and Central Ukraine. The average in the country are the western regions.

We have obtained **integral indicators** using the partial metric method. Comparison of territories with each other is ensured by ranking. Ranking was done by the direct method, when the

seats are determined directly by the magnitude of the indicators. The average score that characterizes the level of saturation of Ukrainian regions by cultural heritage entities was calculated — it is 0,128. On the basis of the integral indicator, the regions are typified by the level of saturation of cultural heritage objects. By the value of this indicator regions of Ukraine can be divided into 5 types: the lowest, lower than average, average, higher than average, highest.

The highest level of saturation of cultural heritage entities is observed in Kiev, Dnipro, Odessa, Kharkiv, the Autonomous Republic of Crimea have higher than the national average and Lviv, Zaporizhzhya, Ivano-Frankivsk, Chernivtsi, Chernihiv and Cherkasy regions are regions that are medium in rich with cultural heritage entities from the State Register of Immovable Monuments of Ukraine. The lowest level of saturation of cultural heritage entities is observed in Rivne, Volyn, Zhytomyr, Kropyvnytskyi, Kherson, Mykolaiv regions.

When performing the data classification, the author used the method of manual intervals. At the same time, depending on the methodology and objectives of the study, experts and developers may use other methods of choropleth classification of data: manual interval, defined interval, equal interval, quantiles, natural breaks, geometric interval, standard deviation. This fact is shown in fig. 5 a set of maps on the Application Stratum and in fig. 7 (AtCH2 prototype). The mentioned methods of division into classes are determined by the amount of data included in each of the classes and the way they are rendered on the map. Classification data schemas use two main components: the number of classes in which data is organized and the method for assigning classes. The number of classes depends on the goal of the analysis.

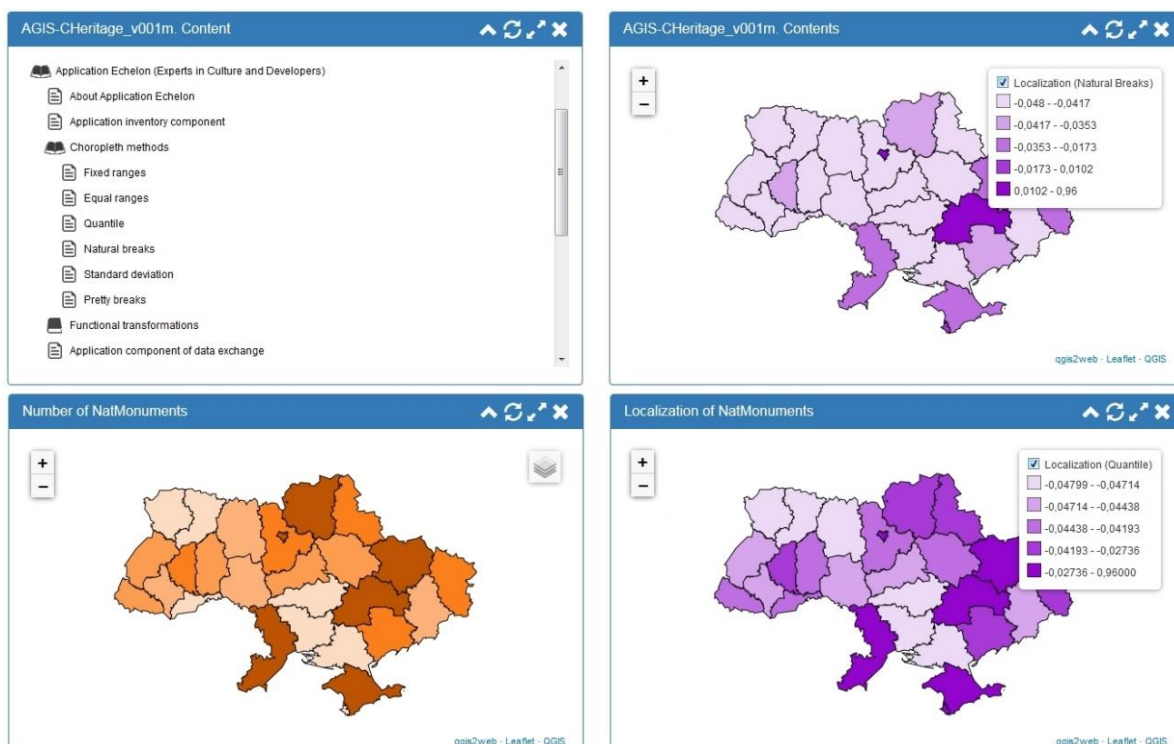

Fig. 7. The result of the use of different choropleth methods: natural breaks and quantiles via AtCH2 prototype (right part)

“Above” the Application Echelon is the AtCH2 Infrastructure Echelon, with elements of which architects, managers, and infrastructure data specialists work, such as NSDI (National Spatial Data Infrastructure, Part of Cultural Data). The vertical hierarchy of the layers corresponds to the amount of knowledge about the relational space of reality modeled by the whole system. From the point of view of the given maps of culture we can speak about change of model. For example, the prototype AtCH2 implemented a model of treemap. Its author [Shneiderman, 1992] defines

treemaps as representations intended to visualize complex traditional tree structures: arbitrary trees that appear as 2-dimensional spatial fillings. The information of choropleth maps can be presented in the form of treemaps and this gives additional knowledge about the object or phenomenon being modeled. The fact of model change is shown in fig. 5 a set of treemaps and maps on the Conceptual Stratum (Infrastructure Echelon) and on the upper right window of AtCH2 prototype — fig. 8.

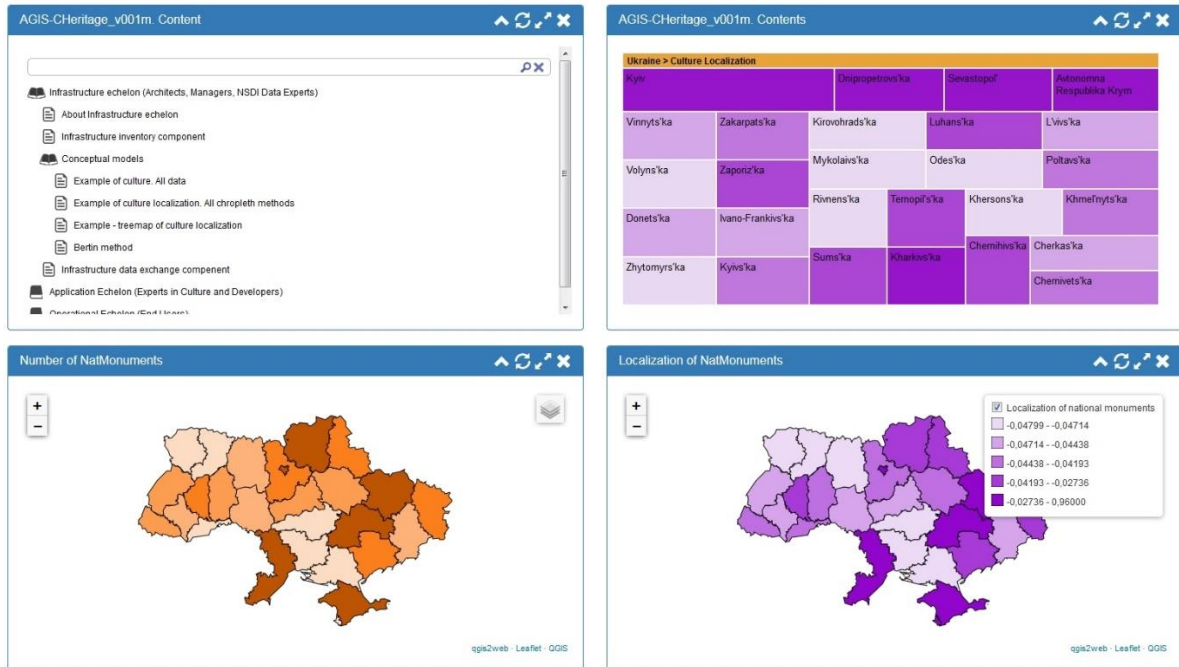

Fig. 8. The result of the use of different models: choropleth maps and treemaps via AtCH2 prototype (right part)

CONCLUSIONS

To better understand the practical results presented here, we refer to the site (http://agiscu.igu.org.ua/AGIS-CH_v001m_AtEx0090eng/indexEng.html, accessed 2019-nov-04). Regarding the theoretical results, note the following:

1. By analogy with the definition of ICA cartography, a modern understanding of the definition of the metacartography is given.

2. The A. Aslanikashvili's meta-model of a map is (can be) a meta-map of the Conceptual stratum of SpIS (or AtS) CoFr of the classical static type. For the classical dynamic type SpIS, the hierarchy of systems must be more complex and involve at least one more stratum. In fact, nothing has been said about it in the work, however, such a statement follows from the AtCH2 prototype at AtEx and from work [Chabaniuk, Dyshlyk, 2016]. So, the Conceptual stratum in that prototype contains Spatial Data Infrastructures. Unlike the classical static type SpIS, these resources must be accessed dynamically.

3. The Language of Map is epistemologically higher of the meta-model of map. According to **Ошибка! Источник ссылки не найден.** the Language of Map is an element of the Abstract world from which meta-models of map by A. Aslanikashvili are generated (can be generated)

REFERENCES

1. Alexander C. The timeless way of building. Oxford University Press, 1979. 552 p.
2. Aslanikashvili A.F. Metacartography. Main problems. Tbilisi: Metsniereba, 1974. 126 p. (in Russian).

3. *Booch G., Jacobson I., Rumbaugh J.* The unified modeling language user guide. Addison-Wesley, 1998. 512 p.
4. *Brackett M. H.* Data resource quality. Boston: Addison-Wesley, 2000. 384 p.
5. *Brambilla M., Cabot J., Wimmer M.* Model-driven software engineering in practice. Morgan & Claypool Publishers, 2017. 2nd Ed. 209 p.
6. *Brodeur J., Coetzee S., Danko D., Garcia S., Hjelmager J.* Geographic information metadata — an outlook from the international standardization perspective. *ISPRS International Journal of Geo-Information*, 2019. V. 8(6). No 280. P. 1–39.
7. *Bunge W.* Theoretical geography: Transl. from English. Moscow: Progress, 1967. 279 p. (in Russian).
8. *Chabaniuk V.* Relational cartography: Theory and practice. Kiev: Institute of Geography, 2018. 525 p. (in Ukrainian).
9. *Chabaniuk V., Dyshlyk O.* Atlas basemaps in Web 2.0 epoch. The International Archives of the Photogrammetry, Remote Sensing and Spatial Information Sciences. XXIII ISPRS Congress, 12–19 July 2016, Prague, Czech Republic. 2016. V. XLI-B4. P. 611–618.
10. *Chabaniuk V., Rudenko L.* Relational geospatial technologies: background theory, practical example and needs in education. *Geospatial Technologies in Geography Education*. Springer. P. 63–83.
11. *Connolly T.M., Begg C.E.* Database systems: a practical approach to design, implementation and management. Pearson Education, 2015. 6th Ed. 1440 p.
12. *Connolly T.M., Begg C.E., Strachan A.D.* Database systems: a practical approach to design, implementation and management. Addison-Wesley, 1995. 839 p.
13. *Cresswell T.* Geographic thought: a critical introduction (Critical introductions to geography). Wiley-Blackwell, 2013. 298 p.
14. *Cultural heritage in atlas geoinformation system of sustainable development of Ukraine*. Kiev: Institute of Geography, 2018. 172 p. (in Ukrainian).
15. *da Silva A.R.* Model-driven engineering: A survey supported by the unified conceptual model. *Computer Languages, Systems & Structures*, 2015. V. 43. P. 139–155.
16. *Favre J.-M.* Megamodelling and etymology. A story of words: from MED to MDE via MODEL in five millenniums. *Dagstuhl Seminar Proceedings 05161*, 427. 22 p.
17. *Hay D.C.* Data model patterns: A metadata map. Morgan Kaufmann, 2006. 432 p.
18. *Information system concepts: an in-depth analysis*. Amsterdam et al., North-Holland, 1989. 357 p.
19. *ISO/IEC/IEEE 24765:2010*. Systems and software engineering — Vocabulary. 410 p.
20. *Karagiannis D., Kuhn H.* Metamodeling platforms. LNCS 2455. Proceedings of the Third Int. Conf. EC-Web at Dexa. Springer, 2002. P. 182–195.
21. *Klir G.J.* Architecture of systems problem solving. Springer, 1985. 540 p.
22. *Liuty A.A.* Language of map: essence, system, functions. Moscow: IG RAS, 2002. 2nd Ed. 327 p. (in Russian).
23. *Marco D.* Building and managing the meta data repository. New York: John Wiley & Sons, 2000. 416 p.
24. *National atlas of Ukraine. Scientific backgrounds of creation and their realization*. Kiev: Academperiodics, 2007. 408 p. (in Ukrainian).
25. *Polyvach K.A.* Cultural heritage and its influence on the development of regions of Ukraine. Kiev: Institute of Geography, 2012. 208 p. (in Ukrainian).
26. *Shneiderman B.* Tree visualization with tree-maps: 2-d Space-Filling Approach. *ACM Transactions on Graphics*, 2012. V. 11. Iss. 1. P. 92–99.
27. *Tannenbaum A.* Metadata solutions. Boston: Addison-Wesley, 2001. 528 p.
28. *van Gigch J.P.* System design modeling and metamodeling. Springer, 1991. 453 p.